

Please check the examination details below before entering your candidate information

Candidate surname

Other names

Centre Number

Candidate Number

Pearson Edexcel
Level 1/Level 2 GCSE (9–1)

--	--	--	--	--

--	--	--	--

Tuesday 21 May 2019

Morning (Time: 1 hour 30 minutes)

Paper Reference **1MA1/1H**

Mathematics

Paper 1 (Non-Calculator)
Higher Tier

You must have: Ruler graduated in centimetres and millimetres, protractor, pair of compasses, pen, HB pencil, eraser.
Tracing paper may be used.

Total Marks

Instructions

- Use **black** ink or ball-point pen.
- **Fill in the boxes** at the top of this page with your name, centre number and candidate number.
- Answer **all** questions.
- Answer the questions in the spaces provided
– *there may be more space than you need.*
- You must **show all your working**.
- Diagrams are **NOT** accurately drawn, unless otherwise indicated.
- **Calculators may not be used.**



Information

- The total mark for this paper is 80
- The marks for **each** question are shown in brackets
– *use this as a guide as to how much time to spend on each question.*

Advice

- Read each question carefully before you start to answer it.
- Keep an eye on the time.
- Try to answer every question.
- Check your answers if you have time at the end.

Turn over ►

P53836A

©2019 Pearson Education Ltd.

6/7/1/1/1/



Pearson

Answer ALL questions.

Write your answers in the spaces provided.

You must write down all the stages in your working.

- 1 There are only blue cubes, red cubes and yellow cubes in a box.

The table shows the probability of taking at random a blue cube from the box.

Colour	blue	red	yellow
Probability	0.2		

The number of red cubes in the box is the same as the number of yellow cubes in the box.

- (a) Complete the table.

(2)

There are 12 blue cubes in the box.

- (b) Work out the total number of cubes in the box.

.....
(2)

(Total for Question 1 is 4 marks)

DO NOT WRITE IN THIS AREA

DO NOT WRITE IN THIS AREA

DO NOT WRITE IN THIS AREA



DO NOT WRITE IN THIS AREA

DO NOT WRITE IN THIS AREA

DO NOT WRITE IN THIS AREA

2 Deon needs 50 g of sugar to make 15 biscuits.

She also needs

three times as much flour as sugar

two times as much butter as sugar

Deon is going to make 60 biscuits.

(a) Work out the amount of flour she needs.

..... g
(3)

Deon has to buy all the butter she needs to make 60 biscuits.

She buys the butter in 250 g packs.

(b) How many packs of butter does Deon need to buy?

.....
(2)

(Total for Question 2 is 5 marks)



3 Find the highest common factor (HCF) of 72 and 90

.....
(Total for Question 3 is 2 marks)

DO NOT WRITE IN THIS AREA

DO NOT WRITE IN THIS AREA

DO NOT WRITE IN THIS AREA



DO NOT WRITE IN THIS AREA

DO NOT WRITE IN THIS AREA

DO NOT WRITE IN THIS AREA

- 4 The diagram shows the plan, front elevation and side elevation of a solid shape, drawn on a centimetre grid.

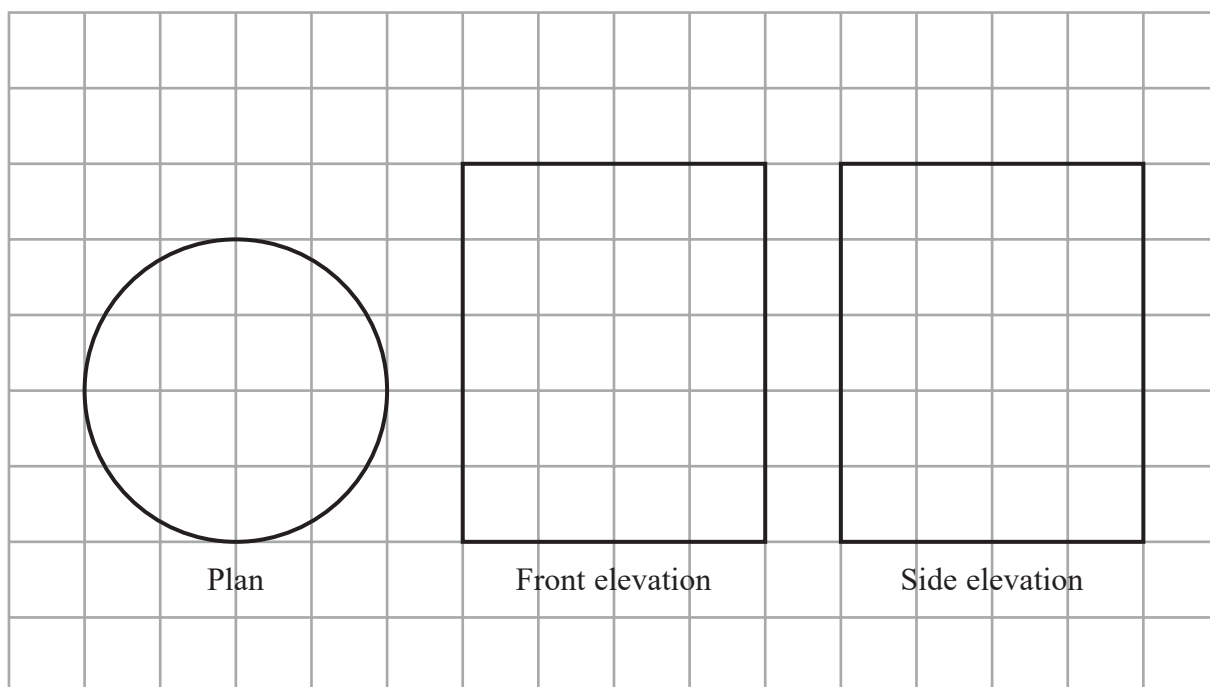

In the space below, draw a sketch of the solid shape.
Give the dimensions of the solid on your sketch.

(Total for Question 4 is 2 marks)



5

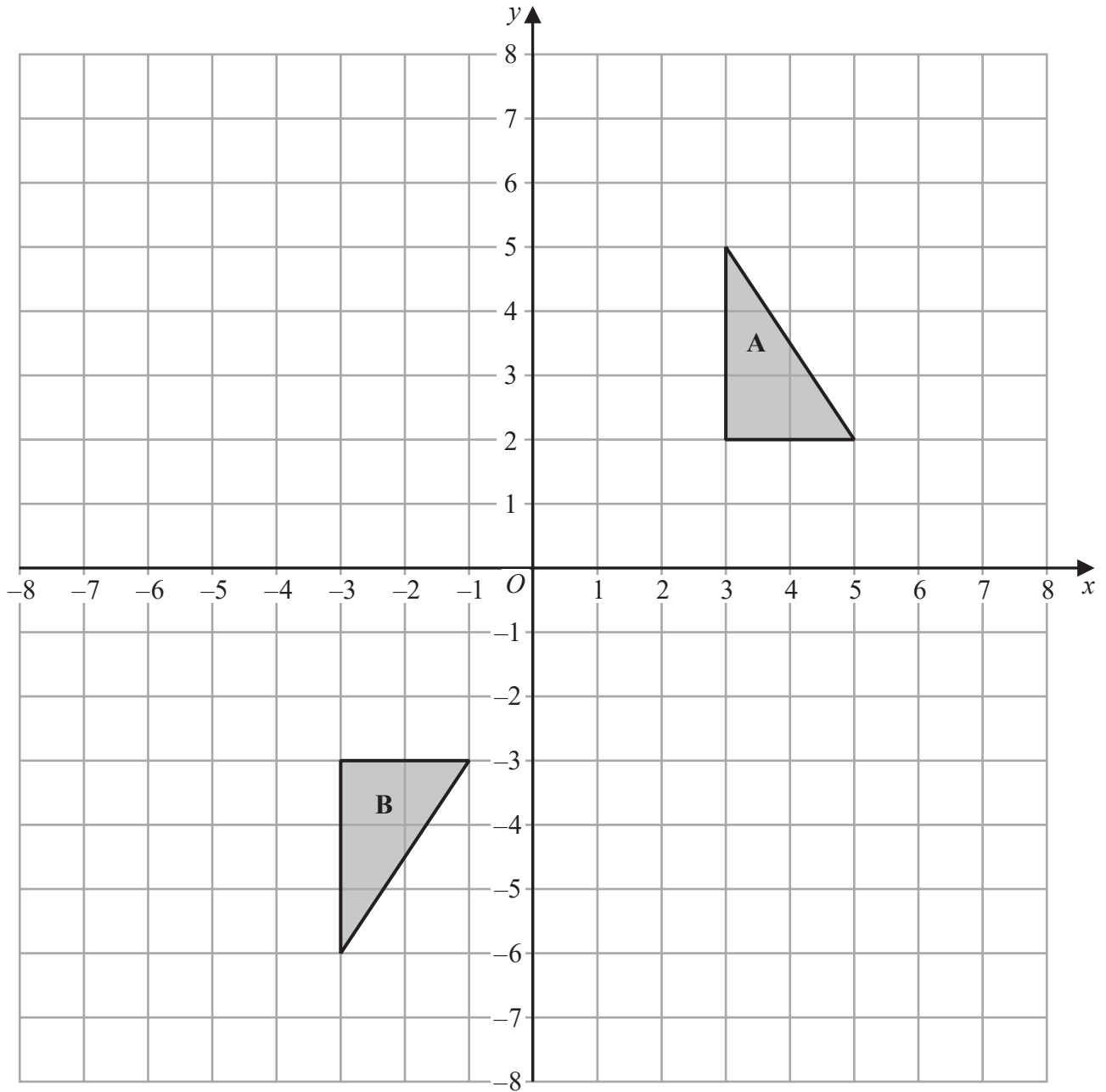

DO NOT WRITE IN THIS AREA

DO NOT WRITE IN THIS AREA

DO NOT WRITE IN THIS AREA

Shape **A** can be transformed to shape **B** by a reflection in the x -axis followed by a translation $\begin{pmatrix} c \\ d \end{pmatrix}$

Find the value of c and the value of d .

$c = \dots\dots\dots$

$d = \dots\dots\dots$

(Total for Question 5 is 3 marks)

6



DO NOT WRITE IN THIS AREA

DO NOT WRITE IN THIS AREA

DO NOT WRITE IN THIS AREA

6 A shop sells packs of black pens, packs of red pens and packs of green pens.

There are

2 pens in each pack of black pens

5 pens in each pack of red pens

6 pens in each pack of green pens

On Monday,

$$\begin{array}{l} \text{number of packs} \\ \text{of black pens sold} \end{array} : \begin{array}{l} \text{number of packs} \\ \text{of red pens sold} \end{array} : \begin{array}{l} \text{number of packs} \\ \text{of green pens sold} \end{array} = 7:3:4$$

A total of 212 pens were sold.

Work out the number of green pens sold.

.....
(Total for Question 6 is 4 marks)



7 Here are two rectangles.

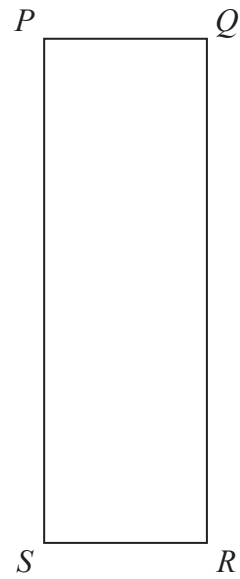
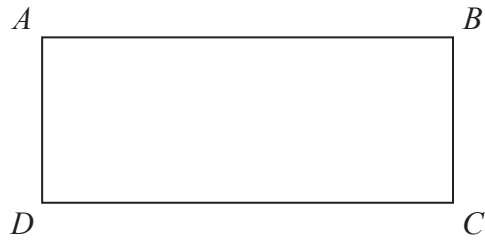

$$QR = 10 \text{ cm}$$

$$BC = PQ$$

The perimeter of $ABCD$ is 26 cm

The area of $PQRS$ is 45 cm^2

Find the length of AB .

..... cm

(Total for Question 7 is 4 marks)

DO NOT WRITE IN THIS AREA

DO NOT WRITE IN THIS AREA

DO NOT WRITE IN THIS AREA



DO NOT WRITE IN THIS AREA

DO NOT WRITE IN THIS AREA

DO NOT WRITE IN THIS AREA

8 (a) Work out an estimate for the value of $\sqrt{63.5 \times 101.7}$

.....
(2)

$(2.3)^6 = 148$ correct to 3 significant figures.

(b) Find the value of $(0.23)^6$ correct to 3 significant figures.

.....
(1)

(c) Find the value of 5^{-2}

.....
(1)

(Total for Question 8 is 4 marks)



9 Work out $3\frac{1}{2} \times 1\frac{3}{5}$

Give your answer as a mixed number in its simplest form.

.....
(Total for Question 9 is 3 marks)

DO NOT WRITE IN THIS AREA

DO NOT WRITE IN THIS AREA

DO NOT WRITE IN THIS AREA



DO NOT WRITE IN THIS AREA

DO NOT WRITE IN THIS AREA

DO NOT WRITE IN THIS AREA

10 The graphs with equations $3y + 2x = \frac{1}{2}$ and $2y - 3x = -\frac{113}{12}$ have been drawn on the grid below.

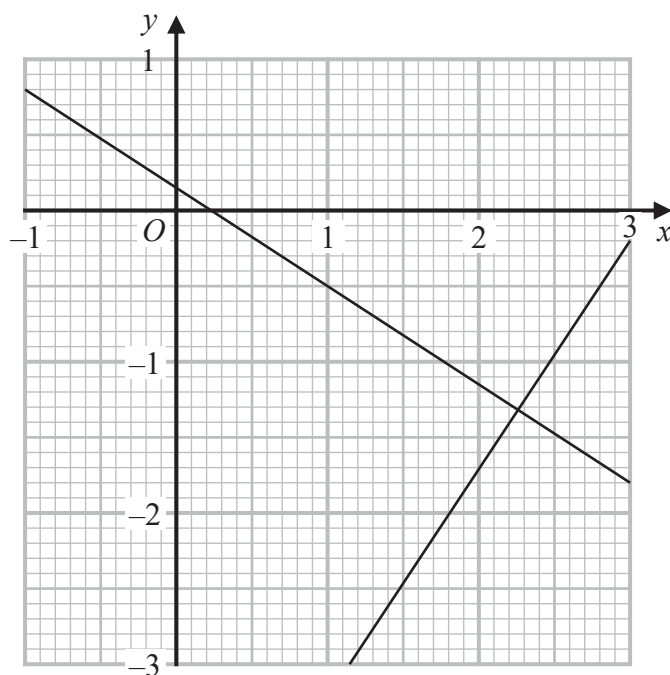

Using the graphs, find estimates of the solutions of the simultaneous equations

$$3y + 2x = \frac{1}{2}$$

$$2y - 3x = -\frac{113}{12}$$

$x = \dots\dots\dots$

$y = \dots\dots\dots$

(Total for Question 10 is 2 marks)



- 11 A bus company recorded the ages, in years, of the people on coach A and the people on coach B.

Here are the ages of the 23 people on coach A.

41 42 44 48 52 53 53 53 56 57 57 59
60 61 63 64 64 66 67 69 74 77 79

- (a) Complete the table below to show information about the ages of the people on coach A.

Median	
Lower quartile	
Upper quartile	
Least age	41
Greatest age	79

(2)

Here is some information about the ages of the people on coach B.

Median	70
Lower quartile	54
Upper quartile	73
Least age	42
Greatest age	85

Richard says that the people on coach A are younger than the people on coach B.

- (b) Is Richard correct?

You must give a reason for your answer.

.....

.....

.....

(1)



Richard says that the people on coach A vary more in age than the people on coach B.

(c) Is Richard correct?

You must give a reason for your answer.

(1)

(Total for Question 11 is 4 marks)

12 Here are three spheres.

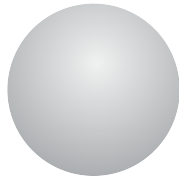

P

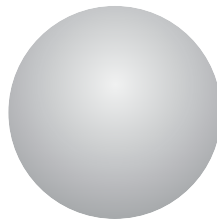

Q

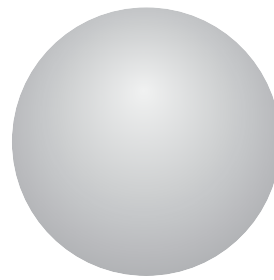

R

The volume of sphere Q is 50% more than the volume of sphere P.

The volume of sphere R is 50% more than the volume of sphere Q.

Find the volume of sphere P as a fraction of the volume of sphere R.

(Total for Question 12 is 3 marks)



13 Given that n can be any integer such that $n > 1$, prove that $n^2 - n$ is never an odd number.

(Total for Question 13 is 2 marks)

14 Find the exact value of $\tan 30^\circ \times \sin 60^\circ$
Give your answer in its simplest form.

(Total for Question 14 is 2 marks)

DO NOT WRITE IN THIS AREA

DO NOT WRITE IN THIS AREA

DO NOT WRITE IN THIS AREA



DO NOT WRITE IN THIS AREA

DO NOT WRITE IN THIS AREA

DO NOT WRITE IN THIS AREA

- 15 The diagram shows a solid shape.
The shape is a cone on top of a hemisphere.

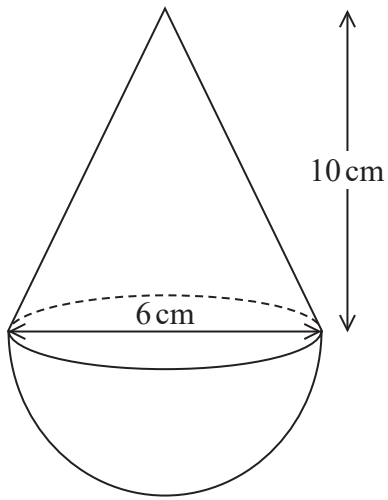

Volume of a cone = $\frac{1}{3} \pi r^2 h$

Volume of a sphere = $\frac{4}{3} \pi r^3$

The diagram shows a cone with radius r and height h . Below it is a sphere with radius r .

The height of the cone is 10 cm.
The base of the cone has a diameter of 6 cm.
The hemisphere has a diameter of 6 cm.

The total volume of the shape is $k\pi \text{ cm}^3$, where k is an integer.

Work out the value of k .

$k = \dots\dots\dots$

(Total for Question 15 is 4 marks)



16 There are three dials on a combination lock.
Each dial can be set to one of the numbers 1, 2, 3, 4, 5
The three digit number 553 is one way the dials can be set, as shown in the diagram.

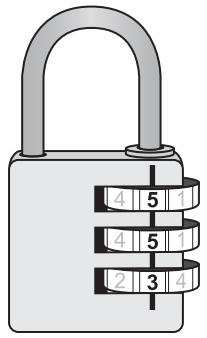

(a) Work out the number of different three digit numbers that can be set for the combination lock.

.....
(2)

(b) How many of the possible three digit numbers have three different digits?

.....
(2)

(Total for Question 16 is 4 marks)



DO NOT WRITE IN THIS AREA

DO NOT WRITE IN THIS AREA

DO NOT WRITE IN THIS AREA

17 Given that

$$x^2 : (3x + 5) = 1 : 2$$

find the possible values of x .

.....
(Total for Question 17 is 4 marks)



18 (a) Express $\sqrt{3} + \sqrt{12}$ in the form $a\sqrt{3}$ where a is an integer.

.....
(2)

(b) Express $\left(\frac{1}{\sqrt{3}}\right)^7$ in the form $\frac{\sqrt{b}}{c}$ where b and c are integers.

.....
(3)

(Total for Question 18 is 5 marks)



DO NOT WRITE IN THIS AREA

DO NOT WRITE IN THIS AREA

DO NOT WRITE IN THIS AREA

19 Given that $x^2 - 6x + 1 = (x - a)^2 - b$ for all values of x ,

(i) find the value of a and the value of b .

$a = \dots\dots\dots$

$b = \dots\dots\dots$
(2)

(ii) Hence write down the coordinates of the turning point on the graph of $y = x^2 - 6x + 1$

(.....,)
(1)

(Total for Question 19 is 3 marks)



20 h is inversely proportional to p
 p is directly proportional to \sqrt{t}

Given that $h = 10$ and $t = 144$ when $p = 6$
find a formula for h in terms of t

DO NOT WRITE IN THIS AREA

DO NOT WRITE IN THIS AREA

DO NOT WRITE IN THIS AREA

.....
(Total for Question 20 is 4 marks)



DO NOT WRITE IN THIS AREA

DO NOT WRITE IN THIS AREA

DO NOT WRITE IN THIS AREA

21 The functions f and g are such that

$$f(x) = 3x - 1 \quad \text{and} \quad g(x) = x^2 + 4$$

(a) Find $f^{-1}(x)$

$$f^{-1}(x) = \dots\dots\dots (2)$$

Given that $fg(x) = 2gf(x)$,

(b) show that $15x^2 - 12x - 1 = 0$

(5)

(Total for Question 21 is 7 marks)



22 There are only r red counters and g green counters in a bag.

A counter is taken at random from the bag.

The probability that the counter is green is $\frac{3}{7}$

The counter is put back in the bag.

2 more red counters and 3 more green counters are put in the bag.

A counter is taken at random from the bag.

The probability that the counter is green is $\frac{6}{13}$

Find the number of red counters and the number of green counters that were in the bag originally.

red counters.....

green counters.....

(Total for Question 22 is 5 marks)

TOTAL FOR PAPER IS 80 MARKS



DO NOT WRITE IN THIS AREA

DO NOT WRITE IN THIS AREA

DO NOT WRITE IN THIS AREA

BLANK PAGE



P 5 3 8 3 6 A 0 2 3 2 4

DO NOT WRITE IN THIS AREA

DO NOT WRITE IN THIS AREA

DO NOT WRITE IN THIS AREA

BLANK PAGE

